

T18P

Entry level Business Class IP Phone



As Standard



As Standard

T18P is a compact IP business phone with the renowned TI Titan chipset. Supporting a feature set that defies its price, the T18P is the intelligent purchase for reliable IP business performance.

T18P

Voice Features

Voice Codecs: G.711, G.723.1, G.726, G.729AB, G.722, VAD, CNG, AEC, PLC, AJB, AGC

Telephony Features

1 VoIP User Account
Direct IP call without SIP proxy
Call Hold
Call Waiting
Call Transfer
Block Anonymous Calls
Hotline
Redial
2 Speed Dials
Volume Control
Call Mute
Ringtone Selection (via web)
Tone scheme
Integrated Voice Response System

Network Features

SIP v1 (RFC2543), v2 (RFC3261)
NAT transverse: STUN mode
IP Assignment: Static/DHCP/PPPoE
In-Band DTMF, Out-of-Band DTMF (RFC2833)
SIP Info
Proxy mode and Peer-to-peer
SIP link mode
TFTP/DHCP/PPPoE client
DNS client
NAT/DHCP server

IP PBX System Integration

Music on Hold
Intercom
Group Paging
Call Pickup
Call Park
Call Forward
DND
Distinctive Ringing
Dial plan
Dial now
Voicemail
Message Waiting Indication (MWI)

Config, Upgrade and Usage

Configuration: browser/phone /auto-provision/IVR
Auto provision via TFTP/FTP/ HTTP/PnP
Auto provision: firmware configuration, ringtone etc.

Security

QoS: IEEE 802.1p/q tagging (VLAN), Layer 3ToS
Digest authentication using MD5/MD5-sess
Secure configuration file via AES encryption
Admin/user configuration mode

Physical Features

TI TITAN chipset
20 keys including 2 programmable keys
4 feature keys (Mute/Redial/ Transfer/Hold)
1xLEDs for power and status indication
1xRJ45 10/100M Ethernet ports
Phone label for speed dialing numbers
Power adapter: AC 100~240V input and DC 5V/1.2A Output
Power over Ethernet (IEEE 802.3af class 1) optional
Operating humidity: 10~95%
Storage temperature: up to 60 C

Package features

Qty/CTN: 5 PCS
N.W/CTN: 7.87KG
G.W/CTN: 9.00KG
Measurement: 0.073CMB
Carton Meas: 470x287x222MM

Certifications

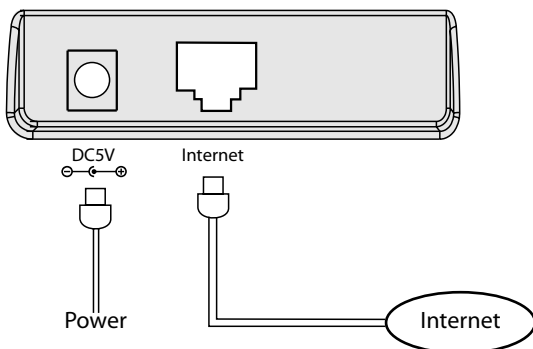
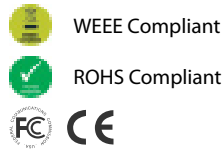

Yealink

EASY VoIP