



Yealink Network Technology CO., LTD

Yealink MVC800&MVC500&MVC300 for Microsoft Teams Rooms
Deployment Guide(V1.2)

Contents

| | |
|---|-----------|
| Introduction..... | 4 |
| Hardware Overview..... | 4 |
| Mini-PC..... | 4 |
| UVC80..... | 5 |
| UVC50..... | 6 |
| UVC30 Room..... | 7 |
| MTouch..... | 7 |
| MShare..... | 8 |
| MSpeaker..... | 9 |
| CP900..... | 10 |
| VCM34..... | 10 |
| Related Documentations..... | 11 |
| Technical Specifications..... | 11 |
| Microsoft Teams Rooms..... | 12 |
| License Requirements for Microsoft Account..... | 12 |
| License Requirements for Using Microsoft Teams Rooms Features..... | 13 |
| | |
| Deployment and Connection..... | 13 |
| MVC800..... | 14 |
| MVC500..... | 14 |
| MVC300..... | 15 |
| Recommended Deployment Solution..... | 16 |
| Deployment Solutions of Different Meeting Rooms..... | 16 |
| Recommendations of Camera Installation..... | 19 |
| Recommendations of MSpeaker Installation..... | 20 |
| Recommendations of Mini-PC Installation..... | 21 |
| Conference Room Wiring..... | 21 |
| | |
| Initial Setup..... | 21 |
| Skype User Account..... | 22 |
| Administrator User Account..... | 22 |
| | |
| Setting up Yealink MVC800/MVC500/MVC300..... | 22 |
| | |
| Basic Settings of Teams Room Systems..... | 24 |
| Controlling UVC80/UVC50/UVC30 Room Camera..... | 24 |
| Enabling/Disabling Auto-framing..... | 25 |
| Controlling UVC80/UVC50/UVC30 Room Camera Position..... | 25 |
| Resetting UVC80/UVC50/UVC30 Room Camera to Home Position..... | 25 |
| Creating the Preset Position on the Yealink RoomConnect Software..... | 25 |
| Setting UVC80/UVC50/UVC30 Room Camera to Preset Position..... | 26 |
| Single and Dual External Display..... | 27 |
| Single Screen Layouts..... | 27 |
| Dual Screen Layouts..... | 28 |
| Enabling Dual Monitor Mode..... | 28 |

| | |
|--|-----------|
| Content Sharing..... | 29 |
| Wired Content Sharing..... | 29 |
| Wireless Content Sharing..... | 29 |
| Adjusting the MTouch Lightness..... | 31 |
| Changing Sign-in Account..... | 31 |
| Administrator Sign-in..... | 32 |
| | |
| Basic Features for Microsoft Teams Rooms App..... | 33 |
| | |
| Troubleshooting..... | 34 |
| Upgrading System Software..... | 34 |
| Enabling Automatically Windows Update..... | 34 |
| Manually Windows Update..... | 35 |
| General Issues..... | 35 |
| Does the MVC500/MVC800/MVC300 Come with All the Necessary Software Pre-installed?..... | 35 |
| The Room Is Not Enabled for Teams Meetings..... | 35 |
| There Is No Content Displayed on the Second Display..... | 36 |
| Why Can not Click Finish After Completing the Setup Wizard?..... | 36 |
| Any Anti-virus Software Needed to Be Installed on the Mini-PC?..... | 36 |
| Restarting the Device..... | 36 |
| Checking the Status of Your Device..... | 37 |
| | |
| Appendix..... | 37 |

Introduction

Yealink MVC Series is the brand-new video conferencing system released by Yealink that revolutionizes the Microsoft Teams Rooms collaboration experience. Perfectly integrated with Microsoft Teams Rooms and Yealink cutting-edge audio & video solutions, the Yealink MVC Series is deemed to cover all the usage scenarios and provide you with the excellent collaboration experience in the conference room. Consisting of the touch console, content sharing unit, audio and video peripherals, and mini-PC, the Yealink MVC Series enhances the whole meeting experience with the familiar Microsoft Teams Rooms interface and a close-to-zero learning curve, allowing you just to simply walk into the conference room and start your meeting with one-touch join, or type a few names and launch an ad hoc call.

The Yealink MVC800 includes two 360 ° pick-up-range microphones and each MVC800 can connect up to four units and a powerful pan-tilt-zoom camera with 12x optical zoom, to cover up a large conference room.

The Yealink MVC500 includes two wireless microphones and each MVC500 can connect up to four units and a powerful pan-tilt-zoom camera with 5x optical zoom, to cover up a small-to-medium conference room. As a substitute for the wireless microphone, the VCM34 wired microphones are available as well.

The Yealink MVC300 includes a UVC30 Room ultra HD 4K camera with auto framing feature and a CP900 HD full duplex speakerphone covering up to 7 people. MVC300 is perfect suit for focus and small meeting room.

- [Hardware Overview](#)
- [Related Documentations](#)
- [Technical Specifications](#)
- [Microsoft Teams Rooms](#)

Hardware Overview

This chapter provides hardware overview.

- [Mini-PC](#)
- [UVC80](#)
- [UVC50](#)
- [UVC30 Room](#)
- [MTouch](#)
- [MShare](#)
- [MSpeaker](#)
- [CP900](#)
- [VCM34](#)

Mini-PC

The following describes the corresponding ports of mini-PC:

Front Panel of the Mini-PC

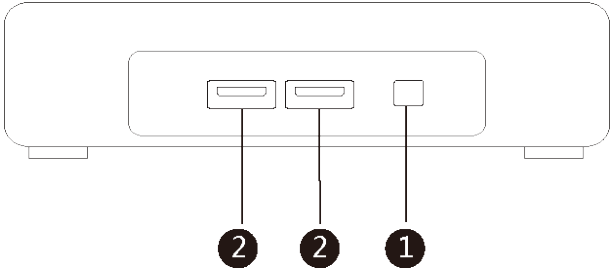

Rear Panel of the Mini-PC

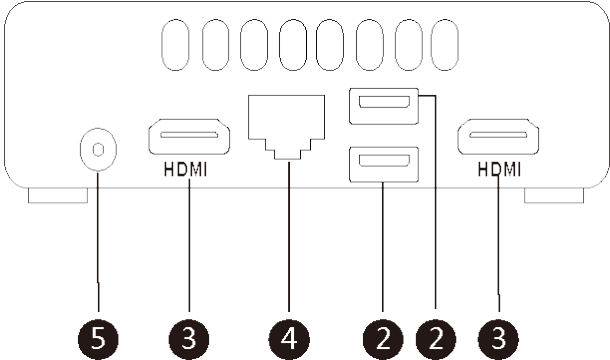

| | Port Name | Description |
|---|--------------|---|
| ① | Power | Powers on or powers off. |
| ② | USB 3.0 Port | <ul style="list-style-type: none"> Connects to the MTouch. Connects to the MShare to share contents. Connects to the UVC80/UVC50/UVC30 Room. Connects to a wireless USB dongle to use the wireless keyboard or the mouse. Connects to the CP900. |
| ③ | HDMI | Connects to a display. |
| ④ | Internet | Connects to the network device. |
| ⑤ | DC19V | Connects to the power adapter. |

UVC80

The following describes the corresponding ports of UVC80:

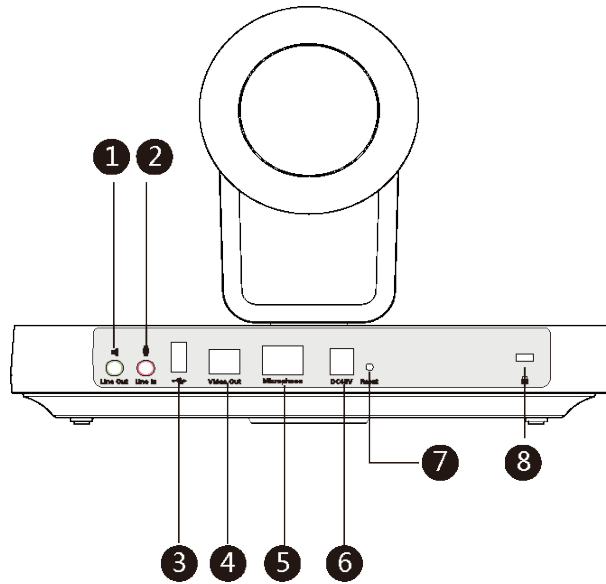

| | Port Name | Description |
|---|---------------|--|
| ① | Line Out | Connects to an audio output device using a 3.5mm audio cable (for example, MSpeaker). |
| ② | Line In | Connects to an audio input device using a 3.5mm audio cable. |
| ③ | USB | Inserts the DD10 to connect to the CPW90. |
| ④ | Video Out | Connects to a PC as a video output. |
| ⑤ | Microphone | Connects to the VCM34. |
| ⑥ | DC48V | Connects to the power adapter. |
| ⑦ | Reset | Resets the UVC80 to factory defaults. |
| ⑧ | Security Slot | Creates a secure connection to the UVC80 with a universal security cable to lock UVC80 down. |

UVC50

The following describes the corresponding ports of UVC50:

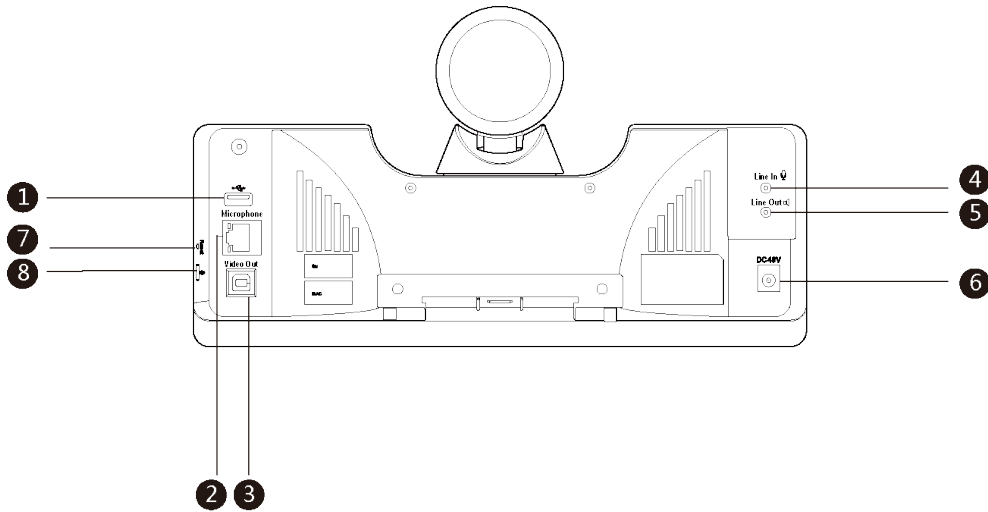

| | Port Name | Description |
|---|---------------|--|
| ① | USB | Inserts DD10 to connect to CPW90. |
| ② | Microphone | Connects to VCM34. |
| ③ | Video Out | Connects to a PC as a video output. |
| ④ | Line In | Connects to an audio input device using a 3.5mm audio cable. |
| ⑤ | Line Out | Connects to an audio output device using a 3.5mm audio cable. |
| ⑥ | DC48V | Connects to the power adapter. |
| ⑦ | Reset | Resets the UVC50 to factory defaults. |
| ⑧ | Security slot | Creates a secure connection to the UVC50 with a universal security cable to lock UVC50 down. |

UVC30 Room

The UVC30 Room is directly connected to the mini-PC via USB cable.

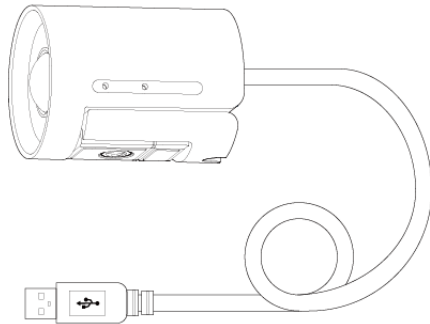

MTouch

The following describes the corresponding ports of MTouch:

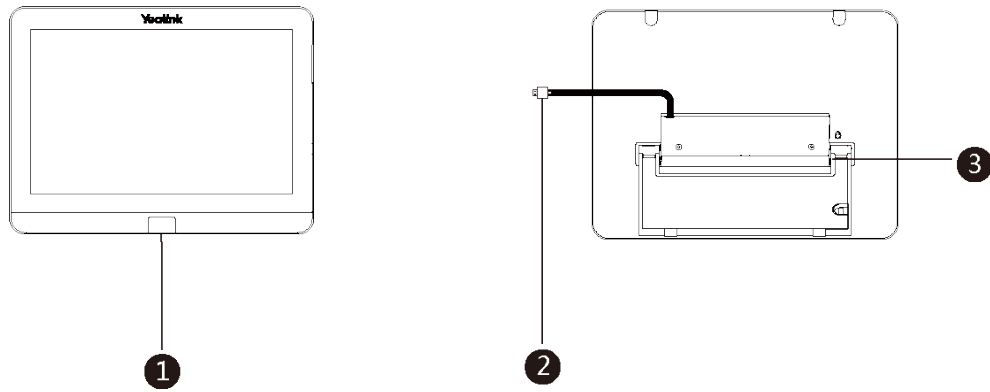

| | Port Name | Description |
|---|---------------------|--|
| ① | Human Motion Sensor | Integrated in the front of the device, the motion detection sensor is to automatically wake up the Yealink MVC system and light up the touch screen when the person approaches the touch screen. |
| ② | USB | Connects to the mini-PC. And the MTouch is powered by mini-PC. |
| ③ | 3.5mm Headset | Connects to a headset. |

MShare

The following describes the corresponding ports of MShare:

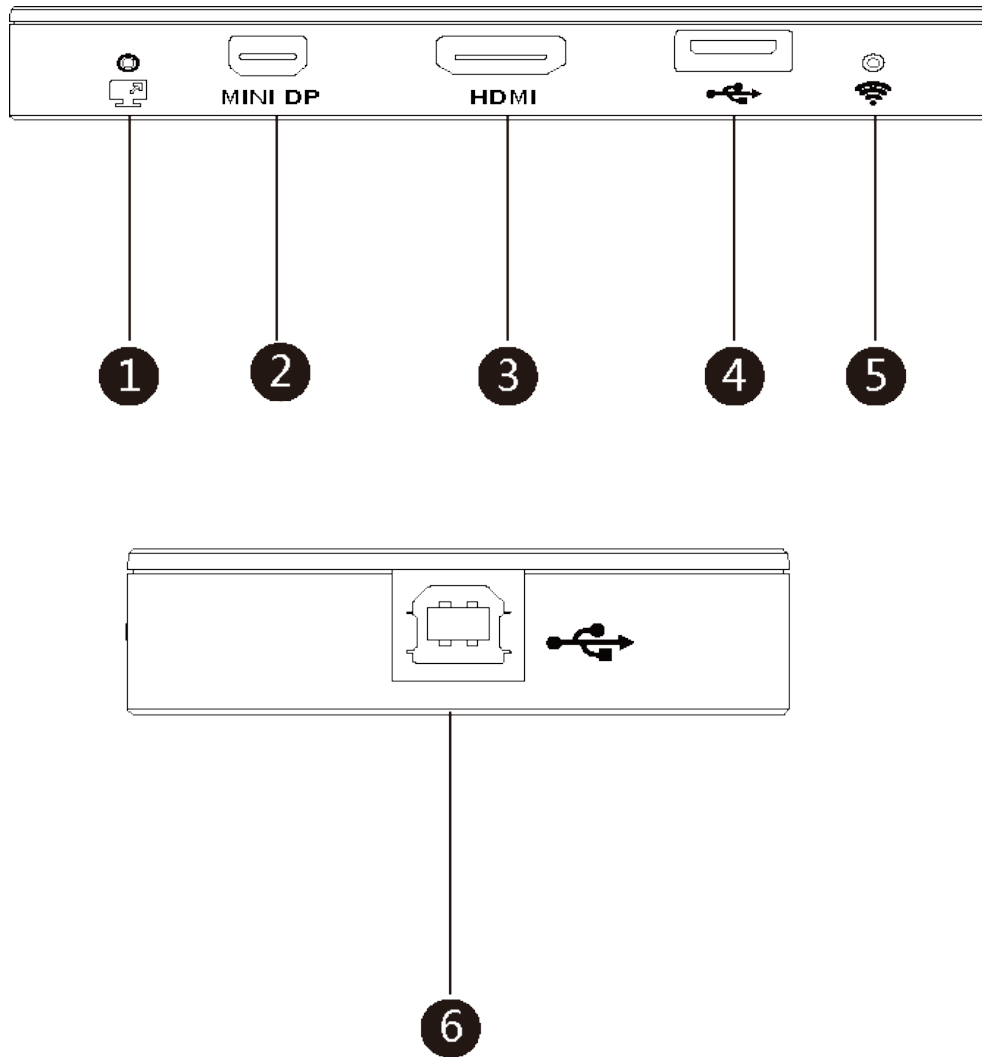

| | Port Name/Indicator Name | Description |
|---|--------------------------|--|
| ① | LED Indicator | Indicates the working status of MShare. |
| ② | Mini DP | Connects to PC to share contents. |
| ③ | HDMI | Connects to PC to share contents. |
| ④ | USB | Connects to WPP20 to pair the WPP20 with the MShare. |
| ⑤ | Wi-Fi AP LED Indicator | Indicates the status of MShare connected to the WPP20. |
| ⑥ | USB | Connects to mini-PC. |

MSpeaker

The following describes the corresponding ports of MSpeaker:

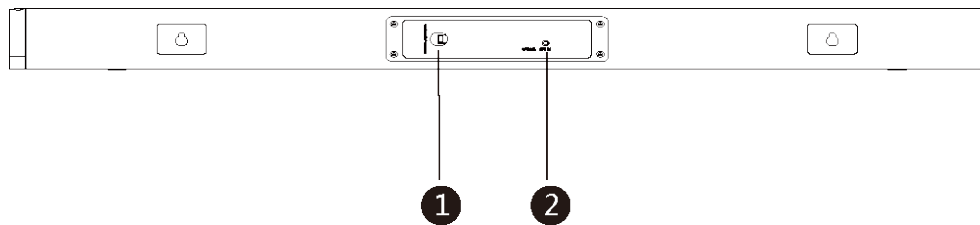

| | Port Name | Description |
|---|-----------|--------------------------------|
| ① | DC100V | Connects to the power adapter. |
| ② | AUX IN | Connects to UVC50/UVC80. |

CP900

The CP900 is directly connected to the mini-PC via USB cable.

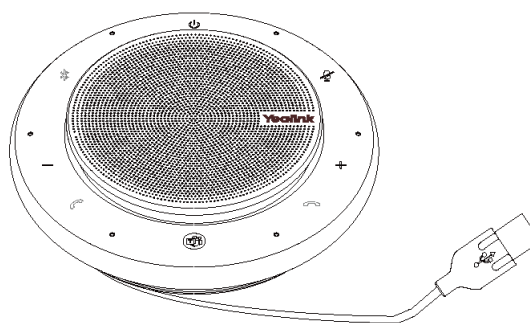

The following buttons are available during Skype for Business and Teams meetings:

| | Button Name | Description |
|---|-----------------------|--|
| ① | Power Button | Tap the power button for 3 seconds to power on or power off the CP900. |
| ② | Volume Up/Down Button | Adjusts the volume of the CP900. |
| ③ | Mute Button | During a call, tap the mute button to mute or unmute. |
| ④ | Hang-up Button | End or reject a call. |
| ⑤ | Answer Button | Answer a call. |

VCM34

The following describes the corresponding ports of VCM34:

| | Port Name | Description |
|---|-----------|--|
| ① | RJ45 Port | Connects to the PoE port of another VCM34 to cascade up VCM34s. |
| ② | PoE Port | <ul style="list-style-type: none"> Connects to UVC80. Connects to the RJ45 port of another VCM34 to cascade up VCM34s. |

Related Documentations

The following related documents are available:

- [Yealink MVC800&500 Quick Start Guide](#)
- [Yealink UVC80 Quick Start Guide](#)
- [Yealink UVC50 Quick Start Guide](#)
- [Yealink UVC30 Room Quick Start Guide](#)
- [Yealink MTouch Quick Start Guide](#)
- [Yealink MSpeaker Quick Start Guide](#)
- [Yealink MShare Quick Start Guide](#)
- [Yealink Mini-PC Box Quick Start Guide](#)
- [Yealink VCM34 Quick Start Guide](#)
- [Yealink CP900 Quick Start Guide](#)
- [Yealink CPW90 Wireless Microphones Quick Start Guide](#)
- [Yealink Room Connect User Guide](#)

Technical Specifications

| | |
|------------------------------|---|
| Operating System | Windows 10 IoT Enterprise |
| Software | Microsoft Teams Rooms |
| Processor / SSD / RAM | 7th Gen Intel® Core™ i5/128GB/8GB (2 x 4GB) |
| Ports | <ul style="list-style-type: none"> • 2 x HDMI video output • Bluetooth and Wi-Fi • 4 x USB3.0 Type-A • 1 x 10/100/1000M Ethernet port • 1 x Power port |
| Buttons | Power On button on the front |
| MTouch | <ul style="list-style-type: none"> • 8-inch IPS screen • 1280 x 800 resolution • 10-point capacitive touch screen • 3.5mm headset jack • Human Motion Sensor • Angle adjustable bracket (23° ~ 50°) |
| UVC80 | <ul style="list-style-type: none"> • 1920 x 1080 video resolution • 60 frame rate • 12x optical zoom • Field of view (diagonal): 78.5° • Pan angle range: 200° • Tilt angle range: 60° |

| | |
|-------------------|--|
| UVC50 | <ul style="list-style-type: none"> • 1920 x 1080 video resolution • 60 frame rate • 5x optical zoom • Field of view (diagonal): 91° • Pan range: 60° • Tilt range: 40° |
| UVC30 Room | <ul style="list-style-type: none"> • 4K video resolution • Maximum 60FPS • 3x digital zoom • Field of view (diagonal): 120° • Facial detection and Auto framing • 1 x 3m USB 2.0 cable |
| MShare | <ul style="list-style-type: none"> • 1080P/30FPS FHD • Support wired and wireless content sharing • Built-in Wi-Fi AP for Yealink wireless presentation device |
| MSpeaker | <ul style="list-style-type: none"> • Output ((THD=1.0%)) RMS: 10W*4 • Frequent response: 60 Hz - 20K Hz • S/N : ≥70dB |
| VCM34 | <ul style="list-style-type: none"> • Built-in 3-microphone array • 20ft (6m) and 360° voice pickup range • Yealink Noise Proof Technology • Power over Ethernet (PoE) • Up to 4 units can be cascaded |
| CP900 | <ul style="list-style-type: none"> • Optima HD voice • Signal to Noise Ratio (SNR): +59 dB • 6.5 feet / 2 meters voice pickup range • Full-duplex technology • Noise suppression (NS) |

Microsoft Teams Rooms

Microsoft Teams Rooms is Microsoft's latest conferencing solution designed to bring a rich, collaborative experience into your meeting room. You will enjoy its familiar Skype for Business and Teams interface and IT administrators will appreciate an easily deployed and managed Windows 10 Skype Meeting app. Microsoft Teams Rooms is designed to leverage existing equipment like LCD panels for ease of installation to bring Skype for Business and Teams into your meeting room. And the system provides a complete meeting experience that brings HD video, audio, and content sharing to meetings of all sizes, from small huddle areas to large conference rooms.

More information available, please visit the [Microsoft Teams Rooms](#).

- [License Requirements for Microsoft Account](#)
- [License Requirements for Using Microsoft Teams Rooms Features](#)

License Requirements for Microsoft Account

| | Type | Requirements |
|---|---------------------------|---|
| ① | On-Premise | Microsoft Exchange 2013+ |
| | | Microsoft Skype for Business Server 2015+ |
| | | Built-in PSTN capability in Lync infrastructure for PSTN dialing |
| ② | Cloud (with PSTN dialing) | Office 365 Enterprise E5 (Skype and PSTN) |
| ③ | Cloud | <ul style="list-style-type: none"> Office 365 Enterprise E1/E3 or Office 365 Skype Premium license Teams Meeting Room License (Microsoft Teams for meeting rooms) |

License Requirements for Using Microsoft Teams Rooms Features

The following table lists the licensing-dependant features that are available in Microsoft Teams Rooms and what licenses you need to buy to get them.

| Microsoft Teams Rooms scenario | You currently have Office 365 Premium, Office 365 ProPlus0, or Skype for Business Standalone Plan 2. | You currently have an Enterprise-based plan. | You have Skype for Business Server 2015 (on-premises or hybrid). |
|--|---|--|---|
| Join a scheduled meeting | Skype for Business Standalone Plan 1 | E1, 3, 4, or 5 | Skype for Business Server Standard CAL |
| Initiate an ad-hoc meeting | Skype for Business Standalone Plan 2 | E1, 3, 4, or 5 | Skype for Business Server Standard CAL Skype for Business Server Enterprise CAL |
| Initiate an ad-hoc meeting and dial out from a meeting to phone numbers | Skype for Business Standalone Plan 2 with Audio Conferencing Note: Communications Credits are optional. | E1 or E3 with Audio Conferencing OR E5 | Skype for Business Standard CAL Skype for Business Server Enterprise CAL |
| Give the room a phone number and make or receive a call from the room or join an audio conference using a phone number | Skype for Business Standalone Plan 2 with Office 365 Phone System and a Calling Plan Note: Communications Credits are optional. | E1 or E3 with Office 365 Phone System and an Office 365 Calling Plan OR E5 | Skype for Business Server Standard CAL Skype for Business Server Plus CAL |

Deployment and Connection

The following contents describe the deployment and connection of MVC800, MVC500, and MVC300.



Note: Make sure the display device is connected first. When starting up the system for the first time, you need to connect a mouse to complete the initial configuration (For MVC300, you need to connect a USB hub to use the mouse). We recommend using the wireless mouse kit.

- [MVC800](#)
- [MVC500](#)
- [MVC300](#)
- [Recommended Deployment Solution](#)

MVC800

The following is the deployment and connection of MVC800.

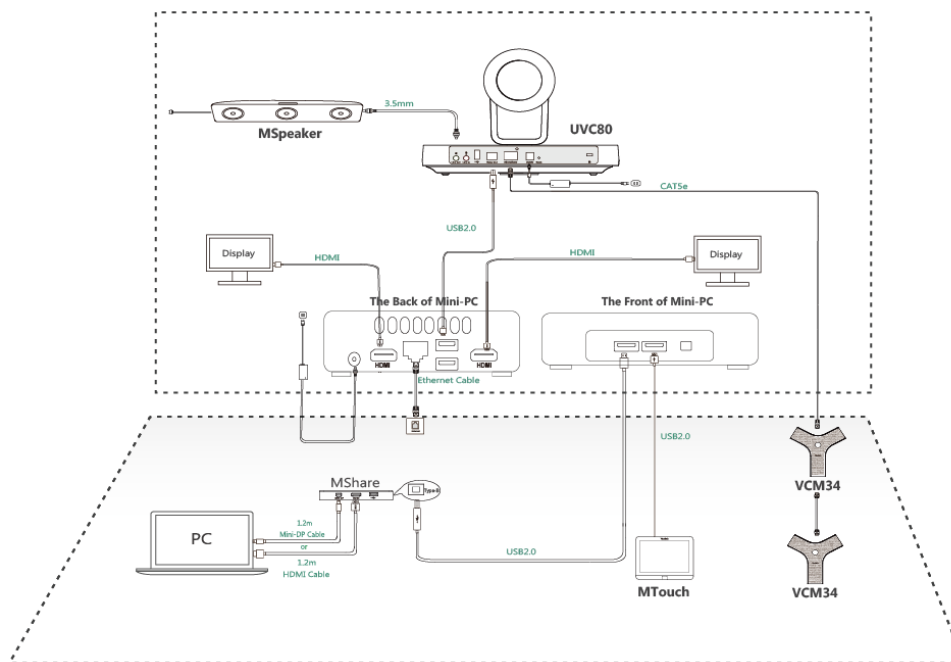

Note:

For more information about the installation and deployment of accessories (for example, the installation of mini-PC package or UVC80 camera), refer to the Quick Start Guide of the corresponding accessory.

MVC500

The following is the deployment and connection of MVC500.

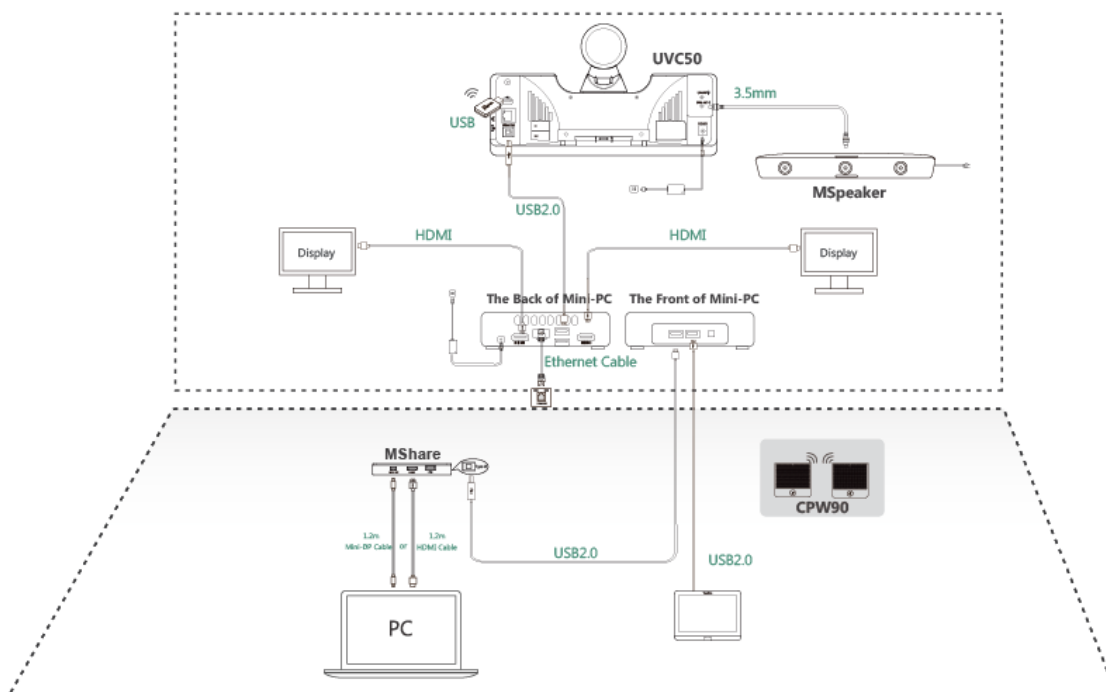

Note:

For more information about the installation and deployment of accessories (for example, the installation of mini-PC package or UVC50 camera), refer to the Quick Start Guide of the corresponding accessory.

MVC300

The following is the deployment and connection of MVC300.

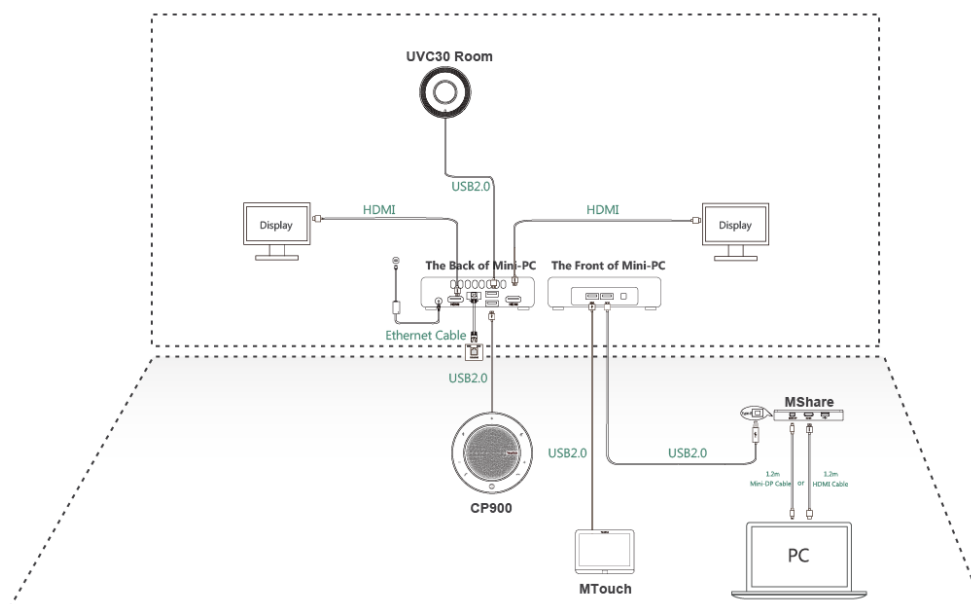

Note:





For more information about the installation and deployment of accessories (for example, the installation of mini-PC package or UVC30 Room camera), refer to the Quick Start Guide of the corresponding accessory.

Recommended Deployment Solution

- [Deployment Solutions of Different Meeting Rooms](#)
- [Recommendations of Camera Installation](#)
- [Recommendations of MSpeaker Installation](#)
- [Recommendations of Mini-PC Installation](#)
- [Conference Room Wiring](#)

Deployment Solutions of Different Meeting Rooms

Yealink MVC800/MVC500/MVC300 system supports different camera devices (UVC80/UVC50/UVC30 Room) and audio devices (VCM34/MSpeaker/CPW90/CP900) according to the conference requirements. Deployment solutions for different camera devices and audio input devices are as follows:

| Medium-to-large room (11-18 People) | Small meeting room (5-7 People) | Small meeting room (5-7 People) | Focus and small room (2-7 People) |
|--|--|---|--|
| MVC800 | MVC500-Wireless | MVC500-Wired | MVC300 |
|  |  |  |  |

For Focus and small room

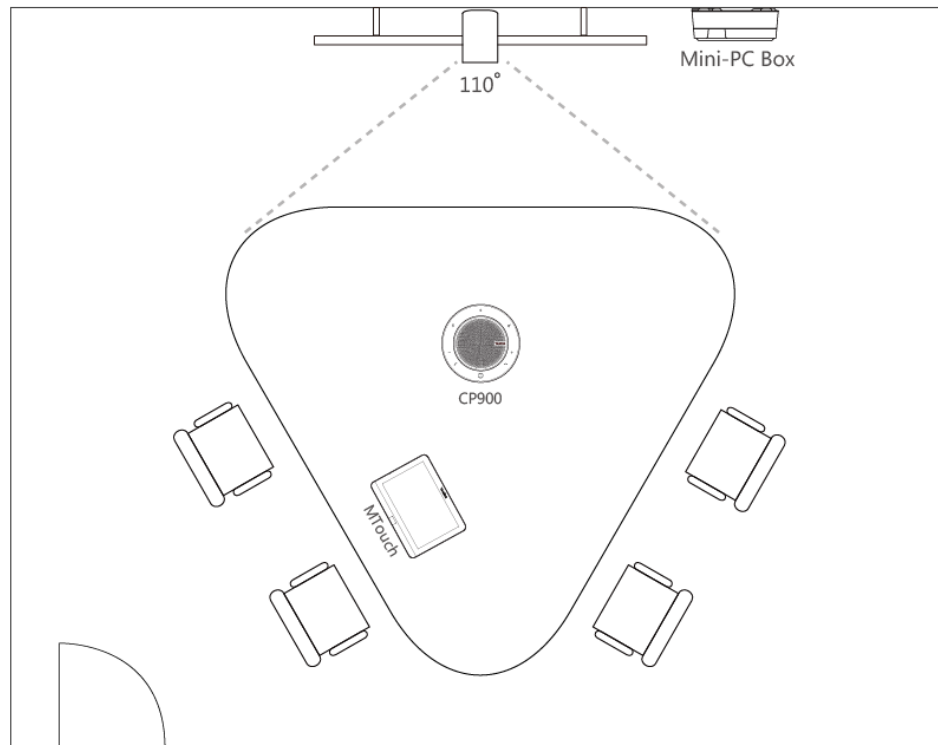

For Small conference room (5-7 people)-Wireless Microphone

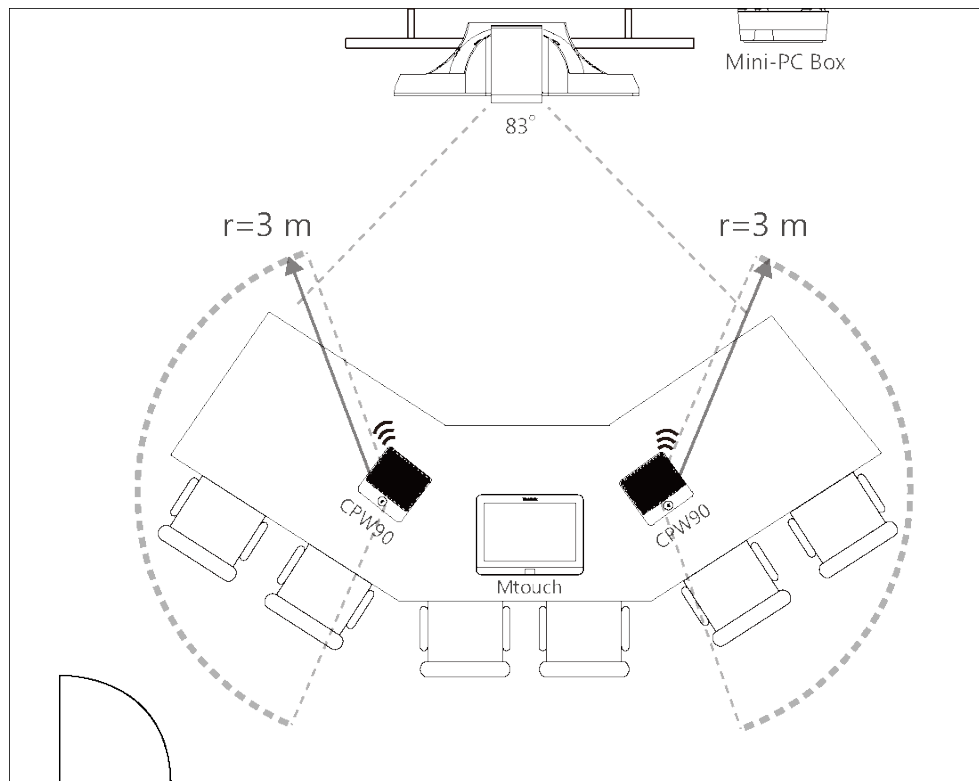

- CPW90 wireless microphones support 360-degree audio pickup at a radius of up to 3 meters.
- Place the CPW90 wireless microphones on a stable surface and keep them away from obstacles, so that they can pick up sounds effectively.

For Small conference room (5-7 people)-Wired Microphone

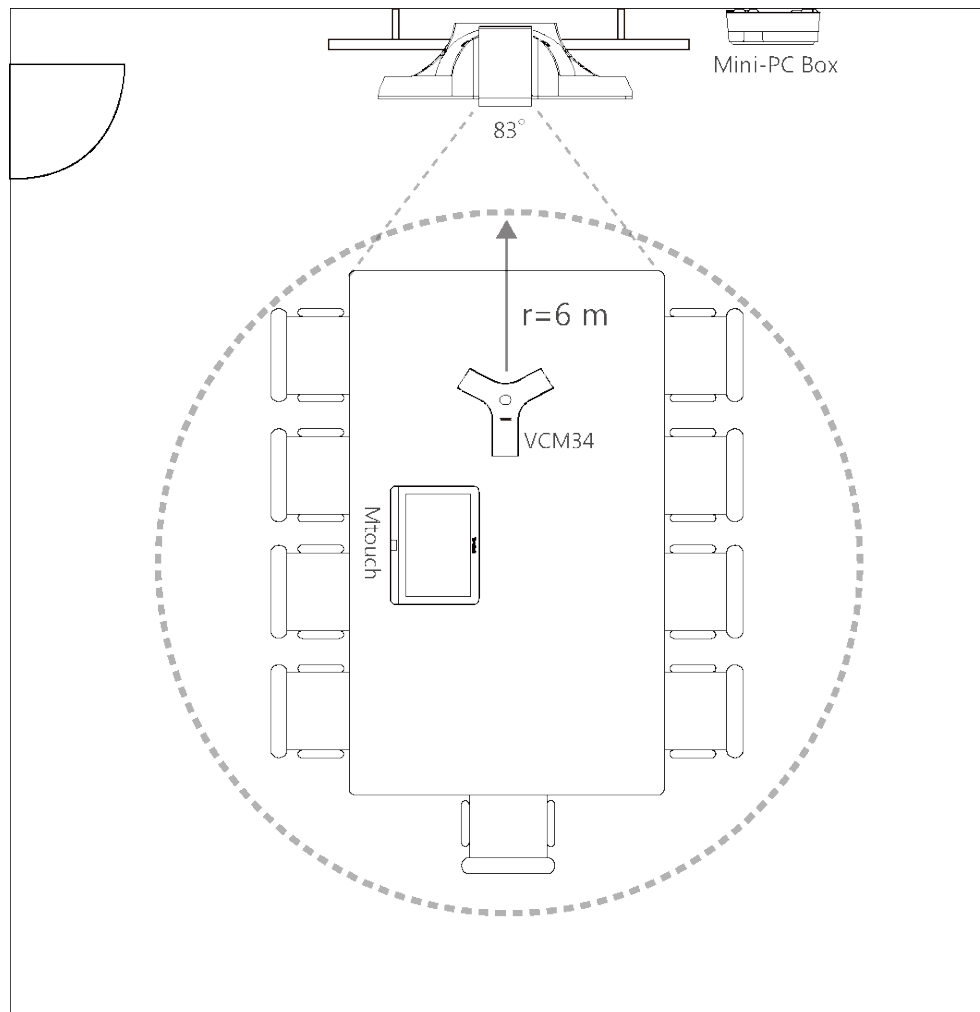

- VCM34 supports 360-degree audio pickup at a radius of up to 6 meters.
- The VCM34 can be replaced with 2 CPW90 wireless microphones.

For Medium-to-large conference room (11-18 people)

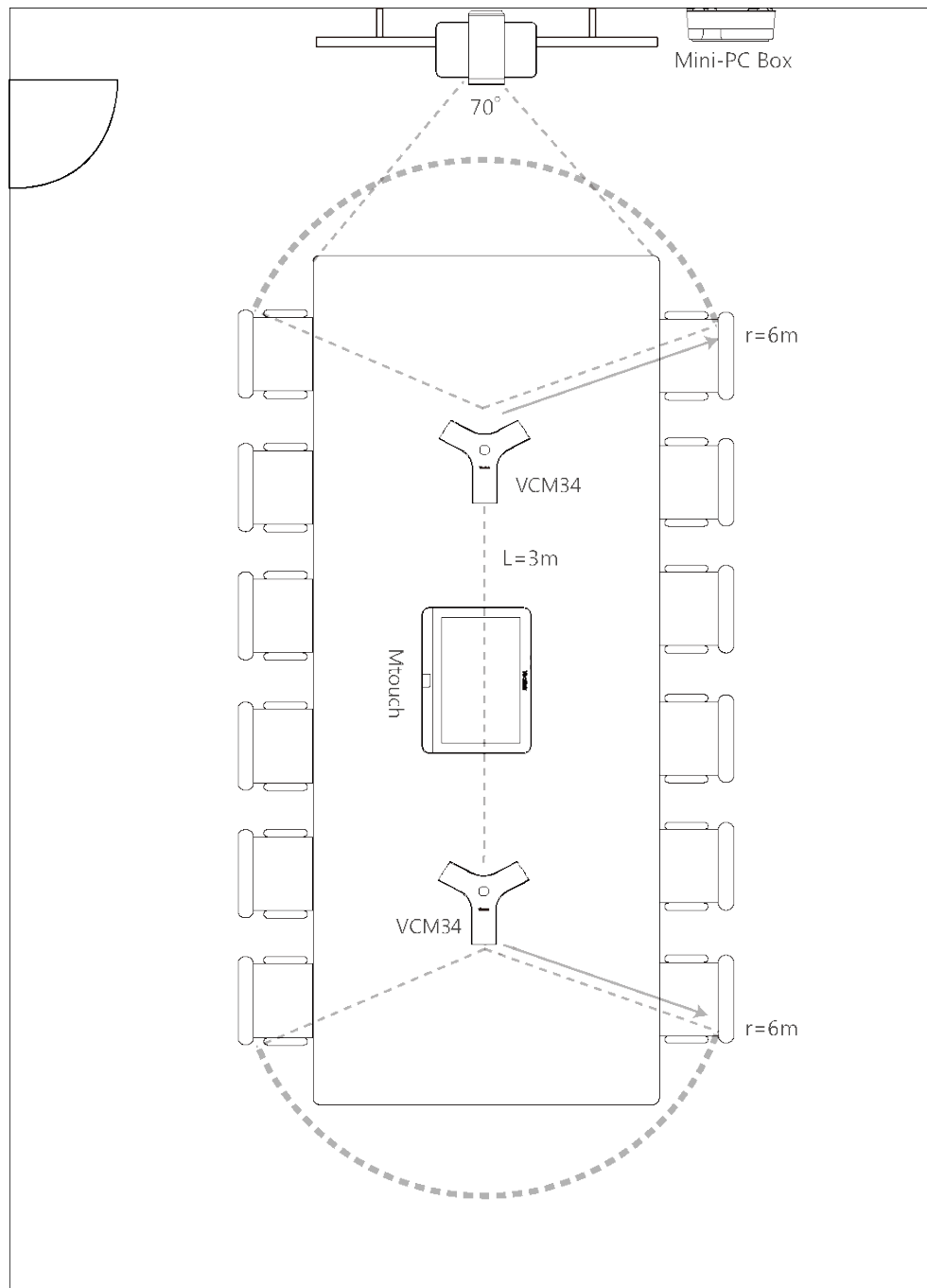

- The distance between the two VCM34s is 3 meters.
- VCM34 supports 360-degree audio pickup at a radius of up to 6 meters and you can cascade up to 4 VCM34 units.



Note: The MTouch needs to be placed in a position facing the door.

Related concepts

[Recommended Deployment Solution](#)

Recommendations of Camera Installation

The following is an example of installing UVC80:

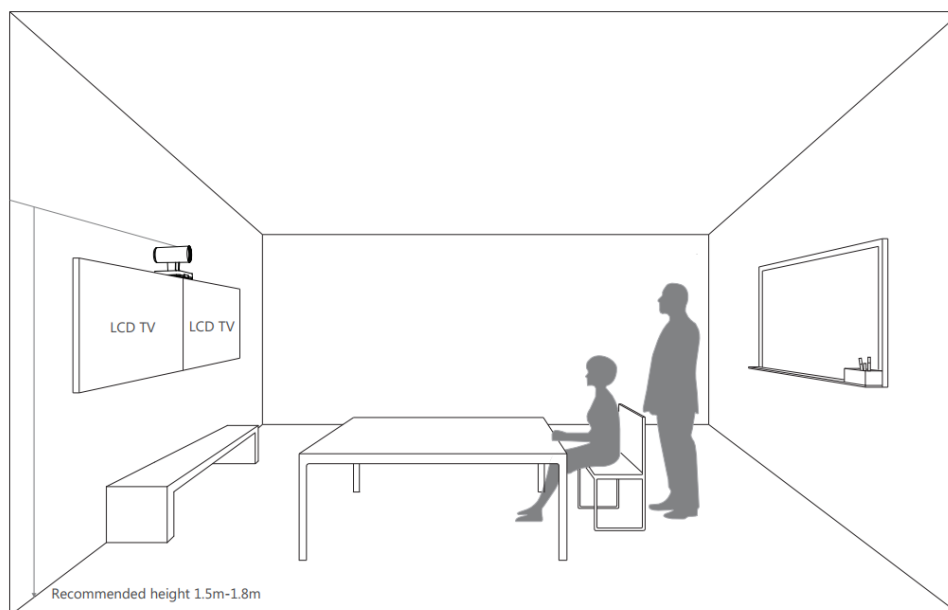

- Install the LCD TV and video camera relative to the center of the participants. Ensure that the participants face the camera and LCD TV directly during calls.
- The camera should be mounted on the wall, about 1.5 m to 1.8 m above the ground. Install the LCD TV below the camera.
- The camera should not face the light source directly, to prevent bad experience caused by dazzling light.

If you purchase the Yealink bracket, the camera can be hung on the Yealink bracket as shown below:

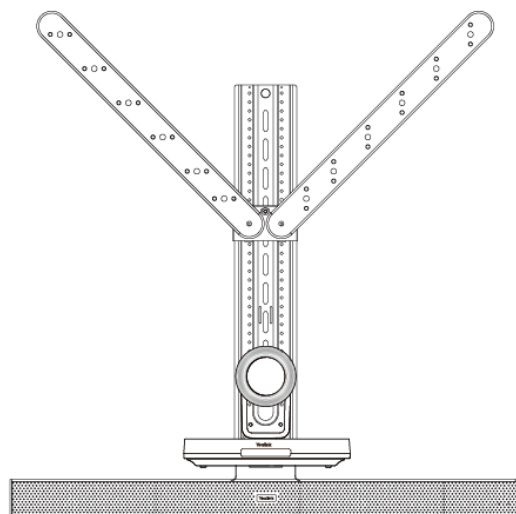

Recommendations of MSpeaker Installation

If you purchase the Yealink bracket, the MSpeaker can be hung on the Yealink bracket as shown below:

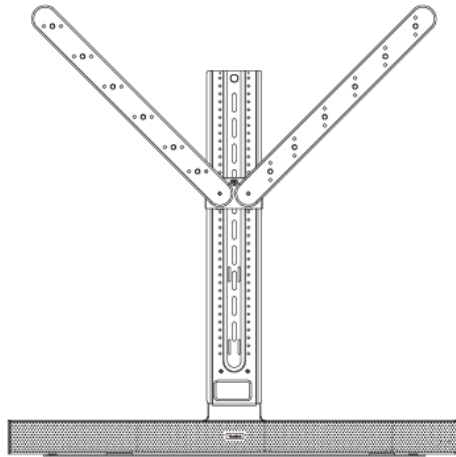

Recommendations of Mini-PC Installation

You can mount the mini-PC on the wall near the TV, or stick it to the table or the backside of the TV cart.

For more information on how to install the mini-PC, please refer to [Yealink Mini-PC Box Quick Start Guide](#).

Conference Room Wiring

If the conference room has a dedicated routing channel, you can follow the real way. If not, follow the way below to route and fix the wire.

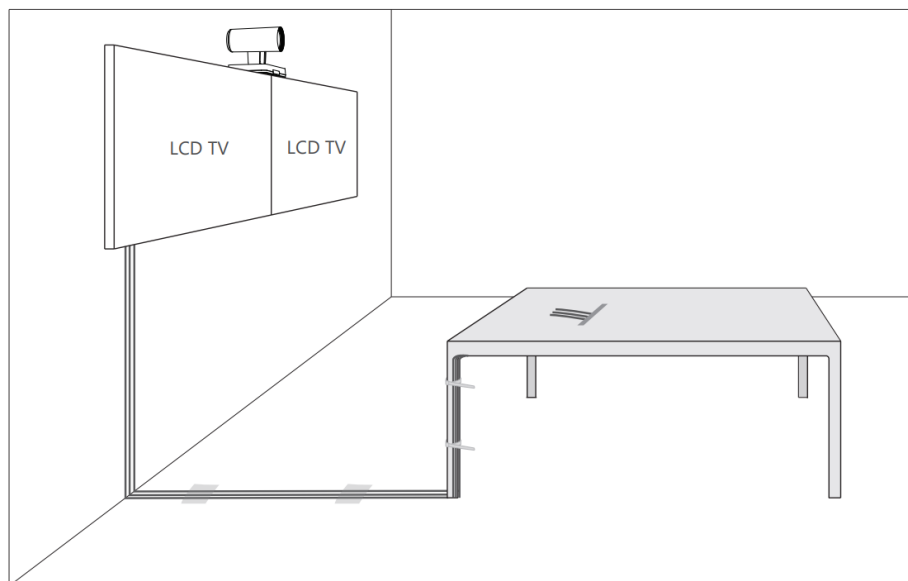

Note: If the cable length exceeds 7 meters, USB extension cables can be used for wiring.

Initial Setup

Once the mini-PC is powered on, the mini-PC will load the Microsoft Windows 10 IoT Enterprise operating system. By default, there are two Windows accounts (Skype user account and administrator user account) built into the MVC system out of the factory.



Note: Before setting up the MVC system, you need to connect a mouse to complete the initial configuration. We recommend using the wireless mouse kit.

- [Skype User Account](#)
- [Administrator User Account](#)

Skype User Account

Skype user account is the default account from which the Microsoft Teams Rooms app runs. This account is limited to running the Microsoft Teams Room app. This account is the default recommended account from which to run Microsoft Teams Room app without a password. No administrator privileges are available from this account.

The default account to run the Microsoft Teams Room is “Skype ” and this account will be automatically signed in when the system boots.

Administrator User Account

Administrator user account is privileged, meaning you can perform any action on the system, with minimal restriction (usually requiring a password for confirmation). The default password is “sfb” without quotes. For daily use such as Skype for Business meetings or Teams meetings, the administrator credentials are not needed. The admin account is only used for device management.

Related tasks

[Administrator Sign-in](#)

Setting up Yealink MVC800/MVC500/MVC300

When the system is powered on, the device will automatically launch the Microsoft Teams Rooms app and enter the sign in screen. To use the device and basic features on the Teams Room Systems, you should finish the setup wizard first.

Before you begin

Make sure all components are connected correctly.

Procedure

1. Tap **Sign in** to enter the **Setup** screen.
2. Check the checkbox in the **Microsoft Software License Terms** page, and then tap **Next**.

Contact your administrator for a permanent license if necessary.

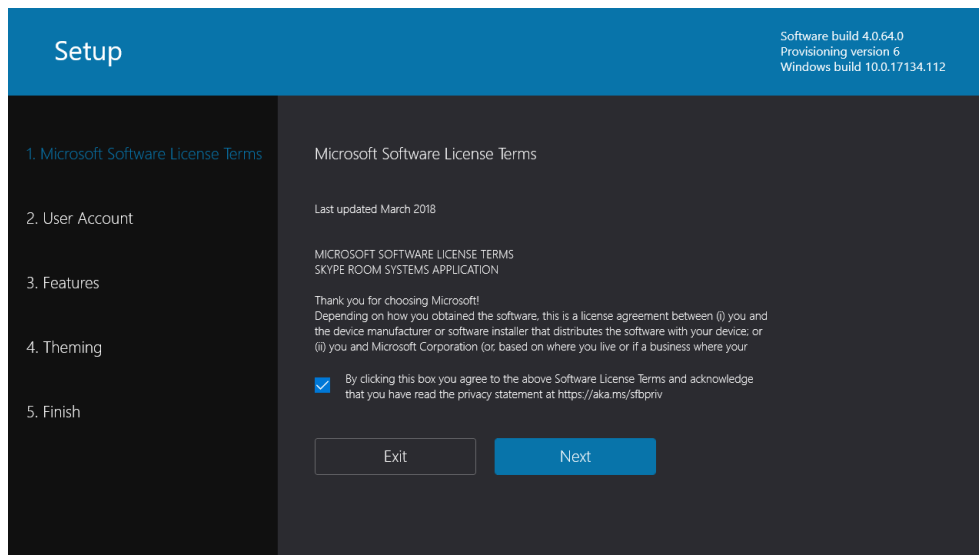

3. Enter the skype account, the password and re-enter the password in the **User Account** page, and then tap **Next**.

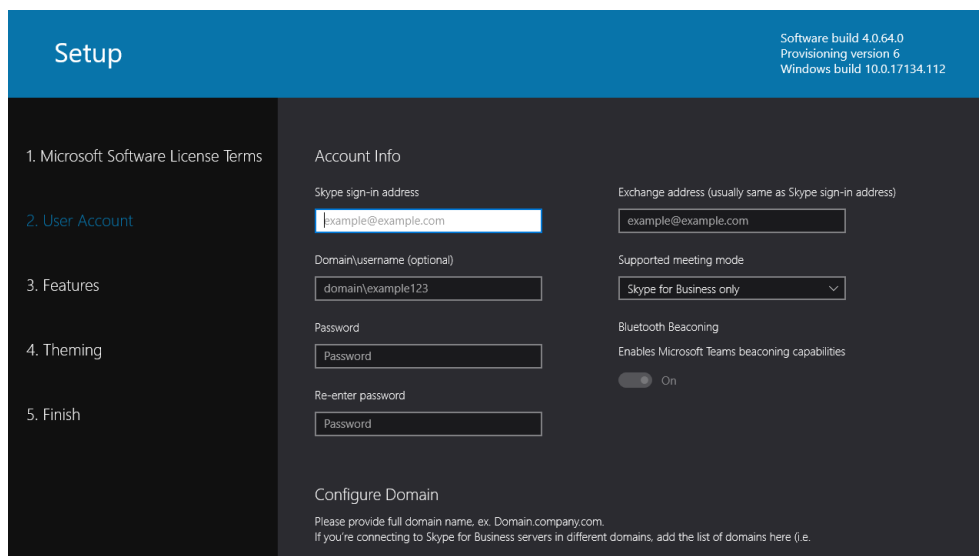

4. Configure the corresponding features and then tap **Next**.

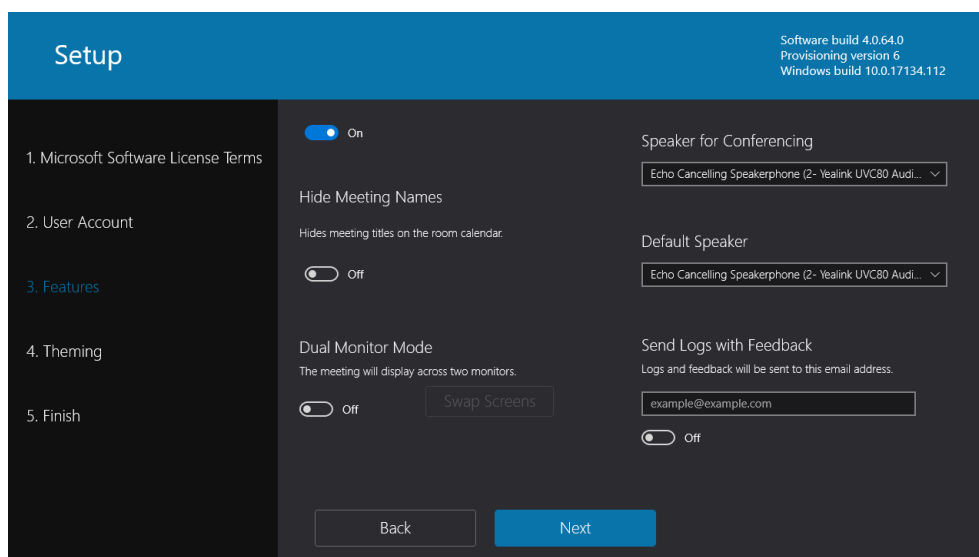

5. Leave the settings in the **Theming** page to **Default** or configure it as you like, and then tap **Next**.

6. Tap **Finish** to complete the setup wizard.

i **Tip:** If you want to use Teams meetings, you can choose the meeting mode to be **Skype for Business and Microsoft Teams (default)** in the **User Account** page.

Basic Settings of Teams Room Systems

This section describes the following basic settings for the Teams Room Systems.

- [Controlling UVC80/UVC50/UVC30 Room Camera](#)
- [Single and Dual External Display](#)
- [Content Sharing](#)
- [Adjusting the MTouch Lightness](#)
- [Changing Sign-in Account](#)
- [Administrator Sign-in](#)

Controlling UVC80/UVC50/UVC30 Room Camera

Microsoft Teams Rooms supports basic PTZ control for your UVC80/UVC50/UVC30 Room camera. In addition, you can use the preset position feature if you set up preset positions for your camera connected to the MVC system on the Yealink RoomConnect software. Camera presets are not applicable to UVC30 Room.

- [Enabling/Disabling Auto-framing](#)
- [Controlling UVC80/UVC50/UVC30 Room Camera Position](#)
- [Resetting UVC80/UVC50/UVC30 Room Camera to Home Position](#)
- [Creating the Preset Position on the Yealink RoomConnect Software](#)
- [Setting UVC80/UVC50/UVC30 Room Camera to Preset Position](#)



Enabling/Disabling Auto-framing

Auto-framing is mainly based on face detection, which provides real-time detection and position tracking on all faces in the conference room. All participants in the output screen are covered and the camera can be automatically adjusted according to the number of participants and the position changes.

About this task

Auto-framing is only applicable to UVC30 Room and is disabled by default. When the auto-framing feature is enabled, you can not control the UVC30 Room camera position.

Procedure



1. Tap  to enter the **Camera Control** page.
2. Select .
3. Enable/Disable the **Auto-framing**.

Controlling UVC80/UVC50/UVC30 Room Camera Position

Before you begin

Only when the auto-framing feature is disabled, can you control the UVC30 Room.

Procedure

1. Tap  to enter the **Camera Control** page.
2. Tap  /  to zoom camera out/in.
3. Tap the arrow keys to pan/tilt the camera.

Resetting UVC80/UVC50/UVC30 Room Camera to Home Position

Procedure

1. Tap  to enter the **Camera Control** page.
2. Tap **Reset**.



Creating the Preset Position on the Yealink RoomConnect Software

Presets specify the settings of both the angle and the focal length for the camera that can be used to quickly point a camera at a pre-defined location. And only administrators have permission to use Yealink RoomConnect. Presets are not applicable to UVC30 Room.

Procedure

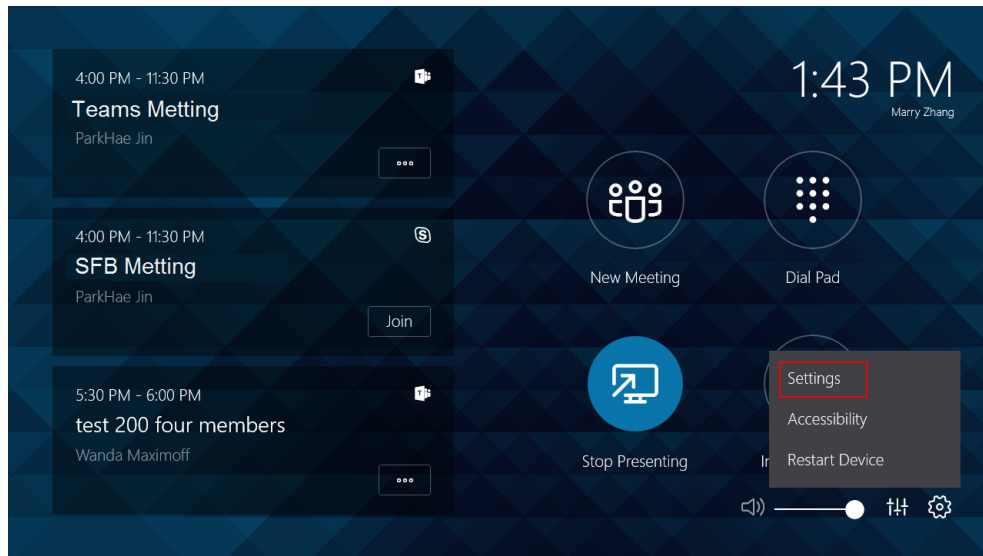
1. Navigate to  > **Settings**.



2. Enter the administrator password (default: sfb) to access the **Setup** screen.
3. Navigate to **Windows Settings** > **Go to Admin Sign-in**.
4. Select **Administrator** from the bottom-left corner.
5. Enter the administrator password (default: sfb) and then sign in.
6. Run the **Yealink RoomConnect** software.
7. Select the desired camera in the **Camera Device** field and then select **Preset Position**.
8. Tap the navigation keys to adjust the camera angle.
9. Tap  or  to adjust the focal length.
10. Tap **New Preset** to create a new preset.

 **Note:** If you are using the Yealink Room Connect for the first time, tap **Skip** to manage the devices locally. You can also manage the devices on the Yealink Device Management Platform or Yealink Management Cloud Service after signing into the remote management account.

For more information on how to use the Yealink RoomConnect software, please refer to [Yealink RoomConnect User Guide](#).

Setting UVC80/UVC50/UVC30 Room Camera to Preset Position

Before you begin

Preset positions have been added in the Yealink RoomConnect software.

About this task

Presets are not applicable to UVC30 Room.

Procedure

1. Tap  to enter the **Camera Control** page.
2. Select a desired preset position.

The camera will be set to the preset position.

Related tasks

[Creating the Preset Position on the Yealink RoomConnect Software](#)

Single and Dual External Display

To fully enjoy video and content sharing in the meeting, at least one external display is recommended to be connected to the mini-PC. If you connect two external displays, the second screen will display the shared content in full screen.



Note: If you want to use two external displays, make sure the dual monitor mode is enabled.

- [Single Screen Layouts](#)
- [Dual Screen Layouts](#)
- [Enabling Dual Monitor Mode](#)

Single Screen Layouts

The following introduces the default layout when you connect one display screen.

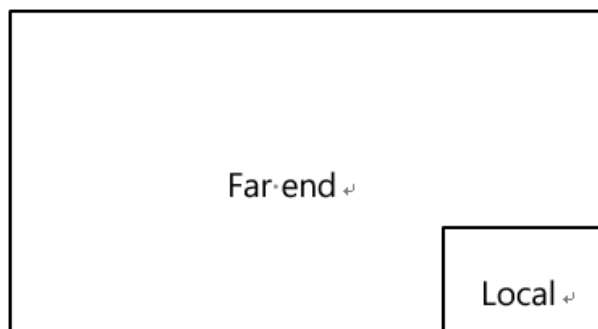
Only Video Calls**Video Calls with a Presentation**

The PC content is given prominence in the largest pane and other participants are displayed beside the PC content.

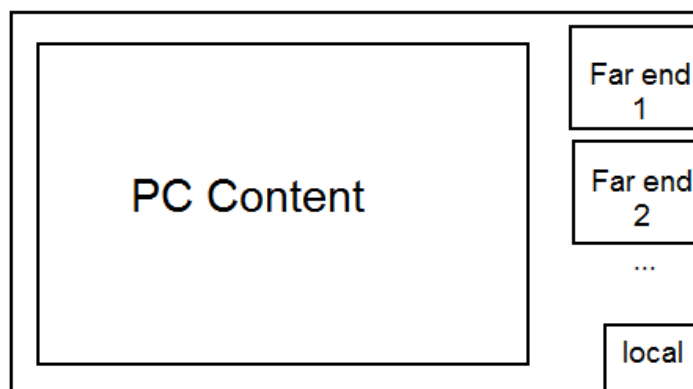

 **Tip:** Tap **Layout** to display the shared content in full screen.

Dual Screen Layouts

The following introduces the default layout when you connect two displays.

One external display displays the remote video feeds and the other display will be reserved for content sharing.

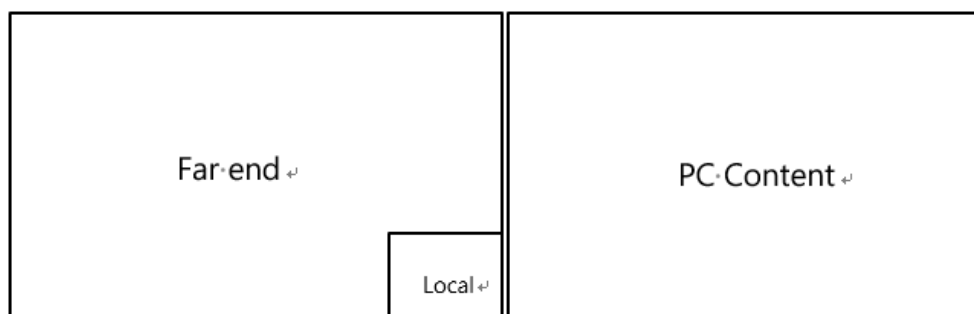

Related tasks

[Enabling Dual Monitor Mode](#)

Enabling Dual Monitor Mode

Before using two external display devices, you should enable dual monitor mode first.

Procedure

1. Navigate to  > **Settings**.

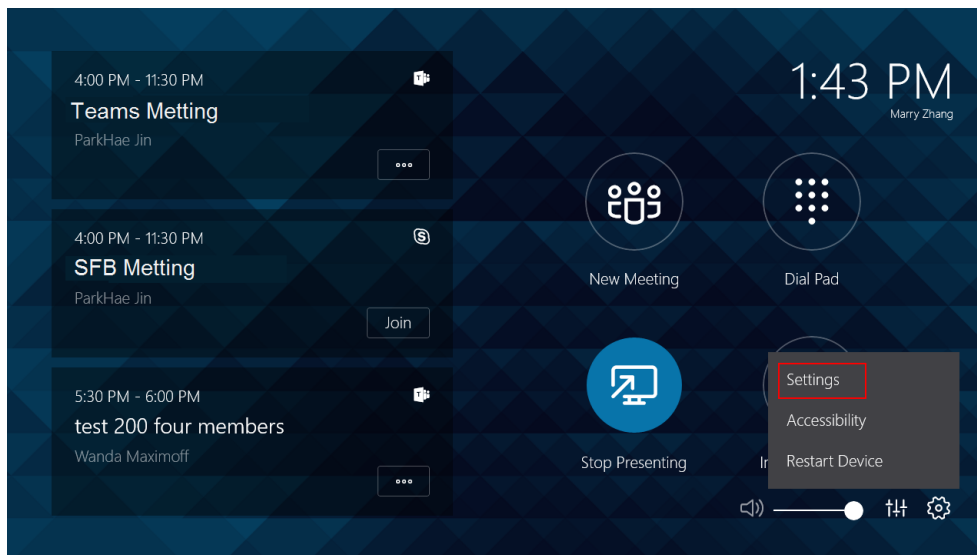

2. Enter the administrator password (default: sfb) to access the **Setup** screen.
3. In the **Features** setting page, enable **Dual Monitor Mode**.
4. Tap **Save and Exit**.

Content Sharing

You can present the content while the device is idle or during a meeting.

- [Wired Content Sharing](#)
- [Wireless Content Sharing](#)

Wired Content Sharing

After the MShare is connected to the PC, you can use MShare for wired content sharing.

Procedure

Do one of the following:

- From the idle screen, tap **Present** to start content sharing.
- During a meeting, tap **Present** to start content sharing with the participants.

Wireless Content Sharing

You can use Yealink WPP20 wireless presentation pod for wireless content sharing. Before content sharing, you should pair the WPP20 with the MShare and then connect it to the computer.

- 📄 **Note:** Only the duplicate display mode is applicable to wireless content sharing and the extended display mode is not applicable when using multiple displays.
- 📄 **Note:** Wireless content sharing is currently not available for Mac OS.
- [Pairing the WPP20 with the MShare](#)

- [Sharing Content via WPP20](#)
- [Stopping Sharing Content via WPP20](#)

Pairing the WPP20 with the MShare

Procedure

1. Connect the WPP20 to the USB port of the MShare.
2. Wait for about 3 seconds, and the WPP20 LED indicator glows solid green.

The WPP20 is paired with the MShare successfully.

Sharing Content via WPP20

Before you begin

Make sure the WPP20 has paired with the MShare.

Procedure

1. Connect the WPP20 wireless presentation pod to your computer.
2. If the WPP20 is first connected to the computer, you need to manually start the Yealink Wireless Presentation Pod software from **This PC** in Windows 10 or from **My Computer** in Windows 7 and then upgrade the WPP20.
 - After starting the software, if it prompts that the firmware is different from the host version, you need to upgrade the WPP20 according to the prompts.
 - For older versions of WPP20, after starting the software, you need to manually upgrade the firmware on the software at the path  -> **Version Update**.

After the upgrade is successful, the WPP20 is ready for content sharing.

3. Do one of the following:
 - On the WPP20, press the presentation button to share the full screen.
 - On the WPP20, long press the presentation button for 3 seconds and then release this button. Select the file or the window you want to share and then click **Start Sharing**.
 - On the Yealink Wireless Presentation Pod software, click Contents Share and choose the file you want to share, and then click **Start Sharing**.

The content you want to share is automatically projected to the device.



Tip: Go to [Yealink website](#) for the latest version of the firmware.

Related tasks

[Pairing the WPP20 with the MShare](#)

Stopping Sharing Content via WPP20

Procedure

Do one of the following:

- On your computer, remove the WPP20.
- On the WPP20, press the presentation button.
- On the Yealink Wireless Presentation Pod software, click **Stop Sharing**.





Tip:

- You can tap **Stop Present** to stop sharing content when the device is idle.
- During a meeting, tap **Stop Presenting** to stop sharing content with the participants.

Adjusting the MTouch Lightness

Procedure

1. Tap  on the idle screen.
2. Tap  and then drag the slider to adjust the lightness of the MTouch.

Changing Sign-in Account

Procedure

1. Navigate to  > **Settings**.

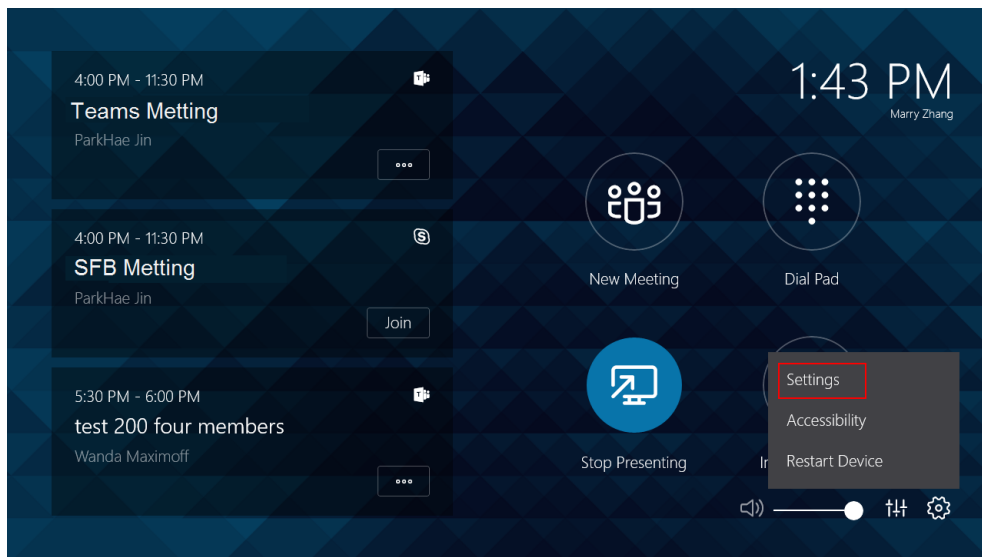

2. Enter the administrator password (default: sfb) to access the **Setup** page.
3. In the **User Account** page, enter the account information in the corresponding field.
4. Tap **Save and Exit**.

The new account will sign in automatically.

Administrator Sign-in

You can sign in as an administrator, and the administrator account provides the system administration capabilities to manage the device.

Procedure

1. Navigate to  > **Settings**.

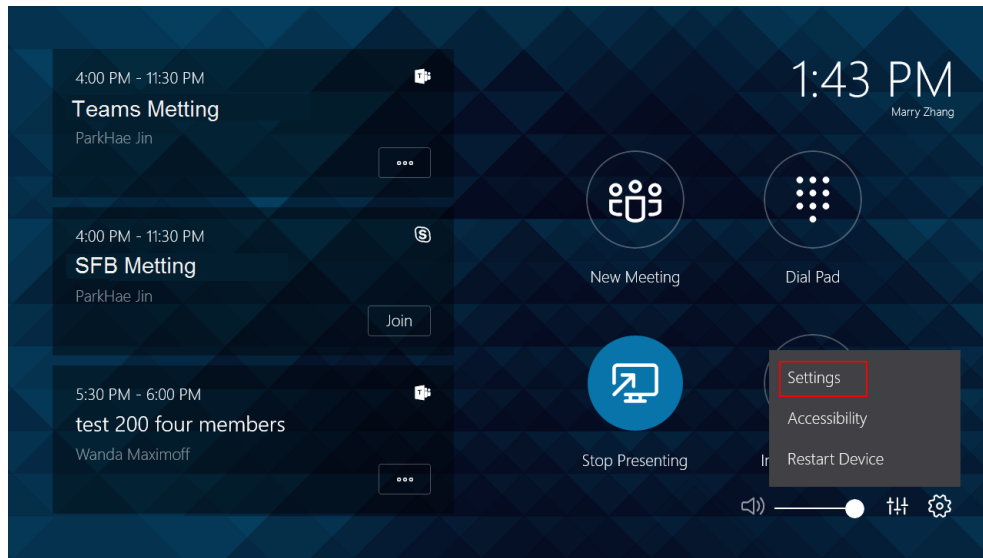

2. Enter the administrator password (default: sfb) to access the **Setup** screen.
3. Navigate to **Windows Settings > Go to Admin Sign-in**.
4. Select **Administrator** from the bottom-left corner.
5. Enter the administrator password (default: sfb) and then sign in.

Basic Features for Microsoft Teams Rooms App

After you set up your device, the touch screen console is displayed on the screen. The touch screen console is the heart of every meeting in the meeting room.

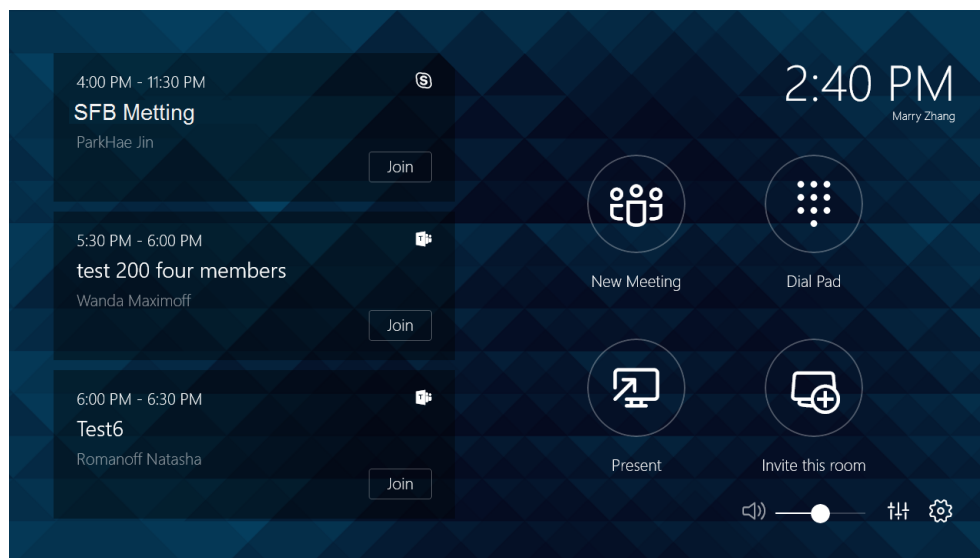

On the screen, you can do the following:

- Join a Skype for Business meeting which is prescheduled via Outlook, where the organizer added the meeting room as the location of the meeting.
- Instantly start a new Skype for Business/Teams meeting by tapping **New Meeting**.
- Make a phone call via **Dial Pad**, using the PSTN calling integration in Skype for Business/Teams meeting.
- Project your PC to the screen in the front of room, by tapping **Present**.
- Invite the room to easily make any meeting a Skype for Business/Teams meeting, instantly projecting to the display in the room and sharing with remote participants.

For more information on how to use the specific features, please refer to [Microsoft Teams Rooms Help](#).

Troubleshooting

This section describes solutions to common issues that may occur while using the Yealink MVC800/MVC500/MVC300. Upon encountering a case not listed in this section, contact your Yealink reseller for further support.

- [Upgrading System Software](#)
- [General Issues](#)
- [Restarting the Device](#)
- [Checking the Status of Your Device](#)



Upgrading System Software

Windows Update is a service provided by Microsoft which provides security updates and functionality updates to Windows operating systems and its installed components. The system software (including the Windows, the UVC80/UVC50/UVC30 Room, the MTouch and the MShare) can be automatically upgraded via windows update by default. Otherwise, you should enable automatically windows update or upgrade the devices manually.

- [Enabling Automatically Windows Update](#)
- [Manually Windows Update](#)



Enabling Automatically Windows Update

Procedure

1. Navigate to  > **Settings**.
2. Enter the administrator password (default: sfb) to access the **Setup** screen.
3. Navigate to **Windows Settings** > **Go to Admin Sign-in**.
4. Select **Administrator** from the bottom-left corner.
5. Enter the administrator password (default: sfb) and then sign in.
6. Tap the  button, and then go to **Settings** > **Upgrade & Security** > **Windows Update**, and select **Advanced options**.
7. Enable **Automatically download updates, even over metered data connections(charge may apply)**.

Manually Windows Update

Procedure

1. Navigate to  > **Settings**.
2. Enter the administrator password (default: sfb) to access the **Setup** screen.
3. Navigate to **Windows Settings** > **Go to Admin Sign-in**.
4. Select **Administrator** from the bottom-left corner and then enter the administrator password.
5. Do one of the following:
 - Long tap the  button and then select **Device Manager**.
 Select the desired device and then long tap the device to select **Update driver**.
 Select the desired way to update.
 - Tap the  button, and then go to **Settings** > **Upgrade & Security** > **Windows Update**, and select **Check for updates**.
 Select the desired device and then complete the installation.

General Issues

- [Does the MVC500/MVC800/MVC300 Come with All the Necessary Software Pre-installed?](#)
- [The Room Is Not Enabled for Teams Meetings](#)
- [There Is No Content Displayed on the Second Display](#)
- [Why Can not Click Finish After Completing the Setup Wizard?](#)
- [Any Anti-virus Software Needed to Be Installed on the Mini-PC?](#)

Does the MVC500/MVC800/MVC300 Come with All the Necessary Software Pre-installed?

The MVC500/MVC800/MVC300 comes with factory imaged Windows 10 IoT and installed with all the necessary software. The only customer requirements are Teams, Skype for Business or Lync credentials to run on the MVC. For more information, refer to [Microsoft Teams Rooms](#).

The Room Is Not Enabled for Teams Meetings

You should enable Teams meeting mode on your system before using the Teams meetings.

Procedure

1. Navigate to  > **Settings**.

2. Enter the administrator password (default: sfb) to access the **Setup** screen.
3. In the **User Account** page, select **Skype for Business (default) and Microsoft Teams** or **Skype for Business and Microsoft Teams (default)** from the **Supported meeting mode** field.
4. Tap **Save and Exit**.

The configuration takes effect after the system restarts.

There Is No Content Displayed on the Second Display

Do one of the following:

- Ensure both displays are properly connected to the HDMI ports on the back of the mini-PC.
- Ensure the **Dual Monitor** mode is enabled on the **Features** settings page.
- Restart the device if necessary.

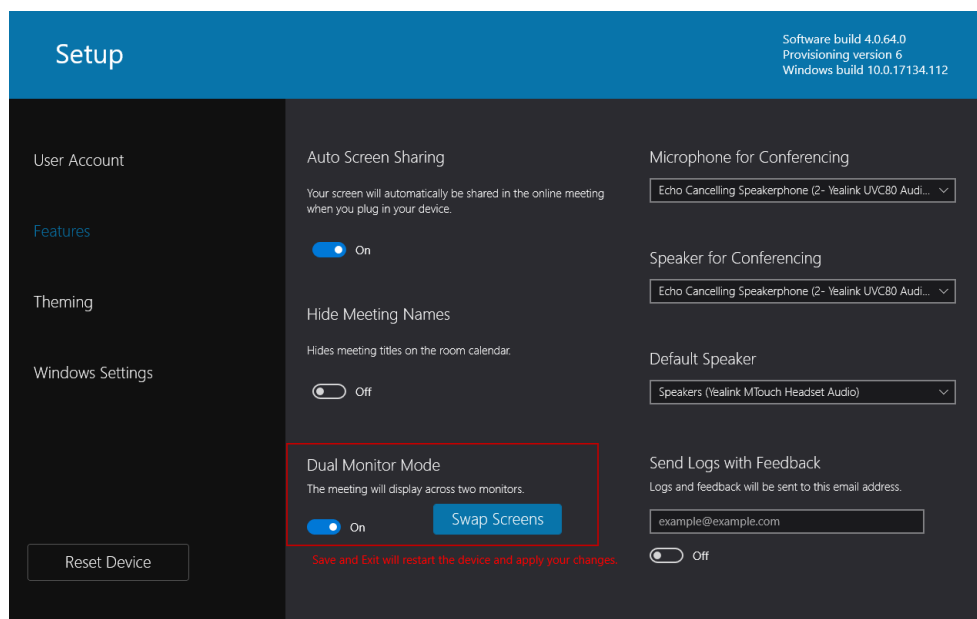

Related tasks

[Enabling Dual Monitor Mode](#)

Why Can not Click Finish After Completing the Setup Wizard?

Ensure that the MShare is connected to your mini-PC.

Any Anti-virus Software Needed to Be Installed on the Mini-PC?

Microsoft itself has Windows Defender, a legitimate antivirus protection plan already built into Windows 10. But not all antivirus software is the same, and you can choose antivirus software based on its ability to defend against threats.

Restarting the Device

After you restart the device, it will automatically launch the Teams Room Systems app and sign in the account.

Procedure

Navigate to  > **Restart Device**.

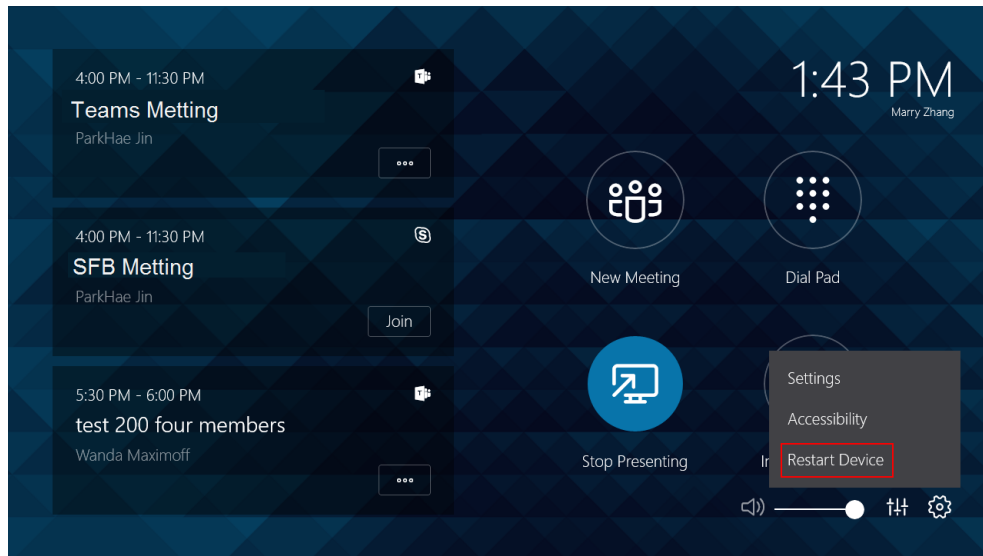

Checking the Status of Your Device

You can view the firmware and hardware of the connected devices (UVC80/UVC50/UVC30 Room, MShare, MTouch and VCM34) on your system.

Procedure

Tap  to enter the **Status** page.

Appendix

Get more about the end-to-end approach to planning, delivering, operating Microsoft Teams Rooms, the deployment of Microsoft Teams Rooms and how to configure a Microsoft Teams Rooms console, see the following links:

- For more information on how to plan Microsoft Teams Rooms, please visit [Plan Microsoft Teams Rooms](#).
- For more information on the deployment of Microsoft Teams Rooms, please visit [Deployment Overview](#).
- For more information on how to configure a Microsoft Teams Rooms console, please visit [Configure a Microsoft Teams Rooms Console](#).