

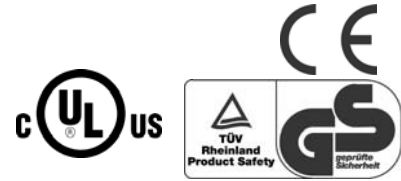

## 19.6W Power Over Ethernet Adapter POE20U High Power single port injector.



### Features

- Fully Compliant detection, disconnect, over load and voltage control IEEE802.3af
- Diagnostic LEDs
- Non-Vented Case
- UNH IOL Test Report
- Full Protection OCP, OVP
- Gigabit Compatible

### Applications

- IP Telephones
- Wireless Network Access Points
- Blue Tooth Access Point
- Security Camera
- IP Print Servers

### Safety Approvals

- cUL/UL
- CE
- TUV

### Mechanical Characteristics

- Length: 140mm (5.51in)
- Width: 65mm (2.55in)
- Height: 36mm (1.42in)
- Weight: 0.2Kg (0.44lb.)

### Output Specifications

Model	DC Output Voltage	Load		Regulation	
		Min.	Max.	Line	Load
POE20U-560(G)	56V	0A	0.35A	54-57VDC	

Ripple And Noise*	Vp-p*
<500Hz	0.5
500Hz-150KHz	0.15
150KHz-500KHz	0.15
500KHz-1MHz	0.1

\*As per IEEE802.3af Table 33-5.

Phihong is not responsible for any error and change. Content is subject to change without notice. Please consult the factory and visit [www.phihong.com](http://www.phihong.com) for the most up-to-date specifications.

**INPUT:**

**AC Input Voltage Range**

90 to 264VAC

**AC Input Voltage Rating**

100 to 240VAC

**AC Input Current**

0.5A(RMS) max. for 90VAC

0.35A(RMS) max. for 240VAC

**Leakage Current**

0.25mA max. @ 254VAC 60Hz

**AC Input Frequency**

47-63Hz

**AC Inrush Current**

15A(RMS) max. for 115VAC

20A(RMS) max. for 230VAC

**OUTPUT:**

**Total Output Power**

19.6W

**Efficiency**

65% (typical) at Max. load, and 120VAC 60Hz

**Hold-up Time**

16mS min. 120VAC and max. load

**Transient O/P Voltage Protection**

60V max. at switch on and off at any AC line Phase

**ENVIRONMENTAL:**

**Temperature**

Operation 0 to +40°C

Non-operation -25 to +65°C

**Humidity**

Operation 5 to 90%

**EMC**

FCC Part 15 Class B

EN55022 Class B

**Isolation Test**

Primary to Secondary: 3000VAC for 1 minute 10mA

Primary to F.G.: 1500VAC for 1 minute

Output to F.G.: 1500VAC

**Immunity**

ESD: EN61000-4-2. Level 3

RS: EN61000-4-3. Level 2

EFT: EN61000-4-4. Level 2

Surge: EN61000-4-5. Level 3

CS: EN61000-4-6. Level 2

Voltage Dips EN61000-4-11

Harmonic: EN61000-3-2

**Insulation Resistance**

Primary to secondary: >10M OHM 500VDC

Primary to FC: >10M OHM 500VDC

**FEATURE:**

**Over Voltage/Current, Short Circuit Protection**

Outputs equipped with short circuit protection and overload protection as per 802.3af specification

The output can be shorted permanently without damage

**Indicators**

Led #1 indicator for input power “on” GREEN

Led #2 Indicator for fault-RED

Led #3 Indicator that Detected and Connected to valid

IEEE802.3af load-GREEN

**Input Connector**

IEC320 inlet 3 pin

**Dimension Diagram Unit: mm (inch)**

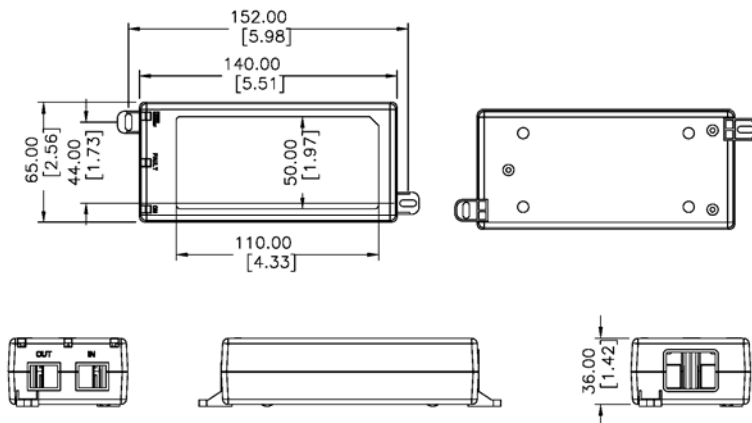



Schematic Block Diagram

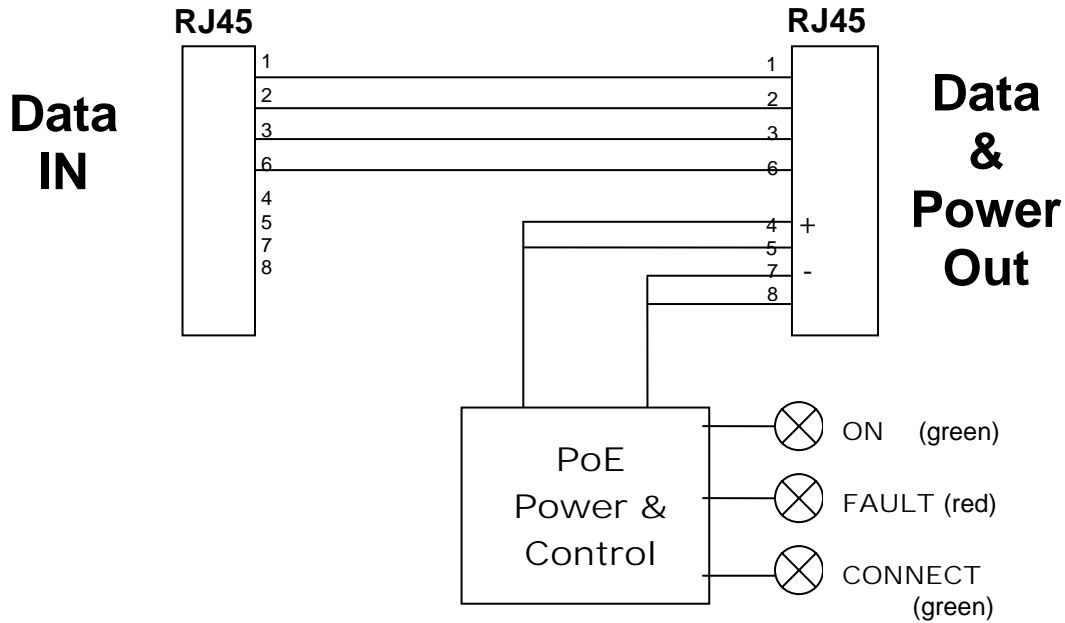

Description of LED Functions

Power-up Sequence:

Upon power-up, all 3 LEDs will light for 2 seconds, as part of the self-test for the internal microprocessor software. After the end of the 2 seconds, the "ON" LED will illuminate green, signifying that the DC output voltage is available for powering a compliant load (to the 802.3af PoE standards).

Detection Sequence:

Once a compliant load is attached to the output RJ45 connector, the green "CONNECT" LED will illuminate.

Should the load be non-compliant then the LEDs will blink a code signifying the cause for non-detection.

Detection Failure Codes:

1. Incorrect resistive signature - The green "CONNECT" and red "FAULT" LEDs will blink 3 times.
2. Incorrect capacitive signature - The green "ON" LED will blink 3 times.
3. Incorrect Voffset - The green "CONNECT" and green "ON" LEDs will blink 3 times.
4. Unstable current measurement - The green "ON" LED will blink 3 times
5. Low voltage sensed during detection (overload) - The red "FAULT" LED will blink 3 times

After the LEDs blink 3 times the adapter will continue to try to detect a valid load. Therefore, until the correct load is applied, the LEDs will continue to blink. If there is an open circuit connected to the output RJ45 then the LEDs will not blink but the adapter will continue to try to detect a valid load.

Fault Sequence:

Should there be a fault such as an overload or short circuit then the red "FAULT" LED will illuminate. The red "FAULT" LED will illuminate for 2 seconds and then go off as the power supply tries to re-detect a valid load. If there is a problem in detecting, the LED will indicate what is wrong with the load as per the codes in the section above.